



**US Army Corps
of Engineers**

Hydrologic Engineering Center

Bridge Hydraulic Analysis with HEC-RAS

19960719 108

Technical Paper No. 151

April 1996

Approved for Public Release. Distribution Unlimited.

DTIC QUALITY INSPECTED 4

Papers in this series have resulted from technical activities of the Hydrologic Engineering Center. Versions of some of these have been published in technical journals or in conference proceedings. The purpose of this series is to make the information available for use in the Center's training program and for distribution within the Corps of Engineers

The findings in this report are not to be construed as an official Department of the Army position unless so designated by other authorized documents.

The contents of this report are not to be used for advertising, publication, or promotional purposes. Citation of trade names does not constitute an official endorsement or approval of the use of such commercial products.

BRIDGE HYDRAULIC ANALYSIS WITH HEC-RAS¹

Vernon Bonner and Gary Brunner
Hydrologic Engineering Center, US Army Corps of Engineers

Introduction

The Hydrologic Engineering Center (HEC) is developing next generation software for one-dimensional river hydraulics. The *HEC-RAS River Analysis System* (HEC, 1995a) is intended to be the successor to the current steady-flow *HEC-2 Water Surface Profiles* Program (HEC, 1990). It will also provide unsteady flow, sediment transport, and hydraulic design capabilities in the future. A single data definition of the river reach and bridge data is used for all modeling methods. The form of the bridge data requirements, the hydraulic routines, and the subsequent research into bridge flow characteristics and modeling approach represent a significant improvement in one-dimensional bridge modeling. This paper provides an overview of HEC-RAS representation of bridge hydraulics and the results of several bridge hydraulics investigations.

HEC-RAS Overview

The HEC-RAS is an integrated package, designed for interactive use in a multi-tasking environment. The system uses a Graphical User Interface (GUI) for file management, data entry and editing, program execution, and output display. The system is designed to provide one-dimensional river modeling using steady-flow, unsteady-flow and sediment-transport computations based on a single geometric representation of the river network. Version 1.1 provides steady-flow water surface profile calculations for a river network with sub-critical, supercritical, or mixed-flow regime

The program has been developed based on a single definition of the river geometric data for all modeling. The five steps for developing a hydraulic model are: 1) create a project file; 2) develop the river network and enter geometric data; 3) define flow and boundary conditions; 4) perform hydraulic analyses; and 5) review results and produce reports. River networks are defined by drawing, with a mouse, a schematic of the river reaches from upstream to downstream. As reaches are connected together, junctions are automatically formed by the program. After the network is defined, reach and junction input data can be entered. The data editors can be called by pressing the appropriate icons in the Geometric Data Window; or reach data can be imported from HEC-2 data sets.

Cross-section data are defined by reach name and river station. Data are defined by

¹Paper for presentation at the Association of State Floodplain Managers' 20th Annual National Conference, San Diego, CA, June 10-14, 1996.

station-elevation coordinates, up to 500 coordinates are allowed. There is no maximum number of cross sections. The cross sections are stored in a downstream order based on their river-station number. Cross sections can be easily added or modified in any order. Cut, copy, and paste features are provided, along with separate expansion or contraction of the cross-section elements of overbanks and channel. Cross-section interpolation is provided using cross-section coordinates. The program connects adjacent cross sections with chords at the boundaries, bank stations, and minimum elevation point. The user can add chords graphically. The interpolated sections are marked in all displays to differentiate them from input data.

Steady-flow data are defined for the reach at any cross-section location. Multiple-profile calculations can be performed. The boundary conditions are defined at downstream, and/or upstream ends of reaches depending on flow regime. Internal boundary conditions are defined at the junctions. Options for starting profile calculations include: known water-surface elevation, energy slope (normal depth), rating curve, and critical depth.

Profile calculations are performed using the standard-step procedure. Overbank conveyance is computed incrementally at coordinate points (HEC-2 style) or at breaks in roughness (HEC-RAS default).² Subcritical, supercritical, and mixed-flow profile calculations can be performed. The critical-depth routine searches the entire range of depths and locates multiple specific energy minima. The location of the transition between supercritical and subcritical flow is determined based on momentum calculations. Detailed hydraulic jump location and losses are not computed; however, the jump location is defined between two adjacent cross sections.

Tabular output is available using pre-defined and user-defined tables. Cross-section tables provide detailed hydraulic information at a single location, for a profile. Profile tables provide summary information for all locations and profiles. Pre-defined summary tables are available for the cross section, bridge, and culvert computations. User-defined tables can be developed, from a menu of 170 output variables, and stored for future use like the pre-defined tables.

Graphical displays are available for cross sections, profiles, rating curves, and a X-Y-Z perspective plot of the river reach, as shown in Figure 1. The geometric data and computed results can be displayed from the View option, provided in most of the data-input editors. User control is provided for variables to plot, line color, width and type, plus axis labels and scales. The user can also zoom-in on selected portions of the display, and zoom-out to the original size. All graphics are in vector form using calls to the Window's™ Graphics Device Interface. Graphics can be sent to output devices through the Windows print manager, or they can be written to a meta file or sent to the Windows clip board.

² Comparisons with HEC-2 results and HEC-RAS using both conveyance calculation methods were presented at *ASCE Hydraulic Engineering '94* (Bonner & Brunner, 1994).

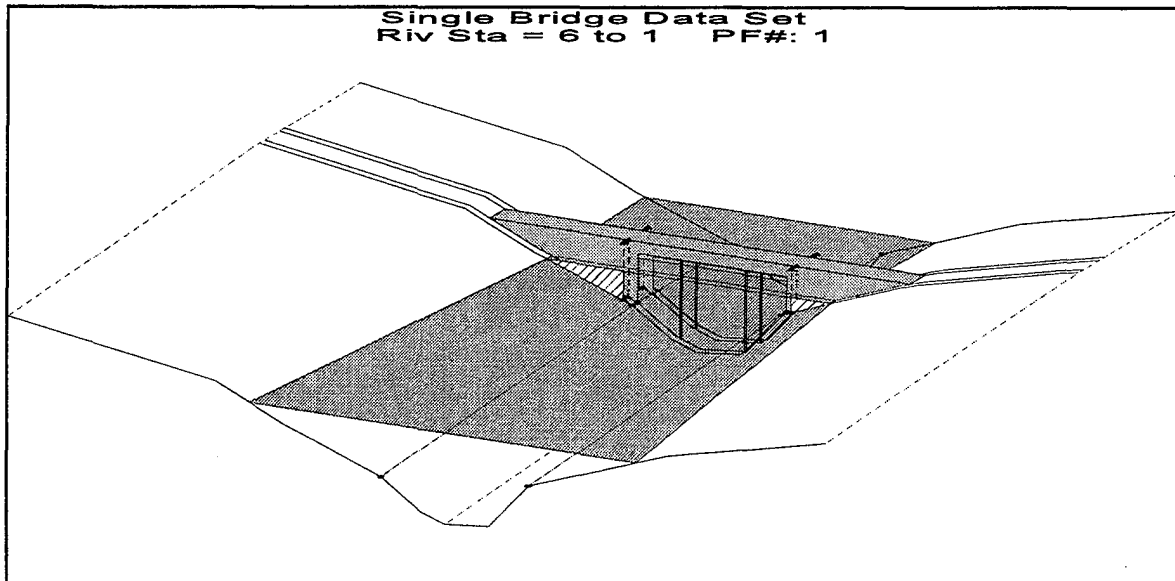

Figure 1. XYZ Plot of Bridge Sections

Bridge and Culvert Routines

The bridge routines in HEC-RAS enables analysis of bridge hydraulics by several different methods without changing the bridge geometry. The model utilizes four user-defined cross sections in the computations of energy losses due to the structure, as shown in Figure 2. An effective-area option is used with the bounding cross sections 2 and 3 to define the ineffective flow areas in those sections (zones marked A-B and C-D in Figure 2). Cross sections are formulated inside the bridge by combining bridge geometry with the two bounding cross sections. The bridge geometry is defined by the roadway/deck, piers, and abutments as separate input items. Bridge data are entered through the editor, shown in Figure 3. The bridge modeling methods are also selected from a menu of options, called from the bridge editor.

Low-Flow Computations. The program first uses the momentum equation to define the class of flow. For Class A low flow (completely subcritical), the modeler can select any or all of the following three methods to compute bridge energy losses: standard-step energy; momentum; or Yarnell equation. The USGS-Federal Highway WSPRO bridge routine (FHWA, 1990) will be included in a later program release. If more than one method is selected, the user must choose a single method as the final solution, or select the method that produces the highest energy loss through the structure. For Class B low flow (passes through critical depth) the program uses the momentum equation. Class C low flow (completely supercritical) can be modeled with either the standard step energy method or the momentum equation. Also, the program can incorporate forces due to water weight and/or friction components in addition to the pier impact losses for momentum.

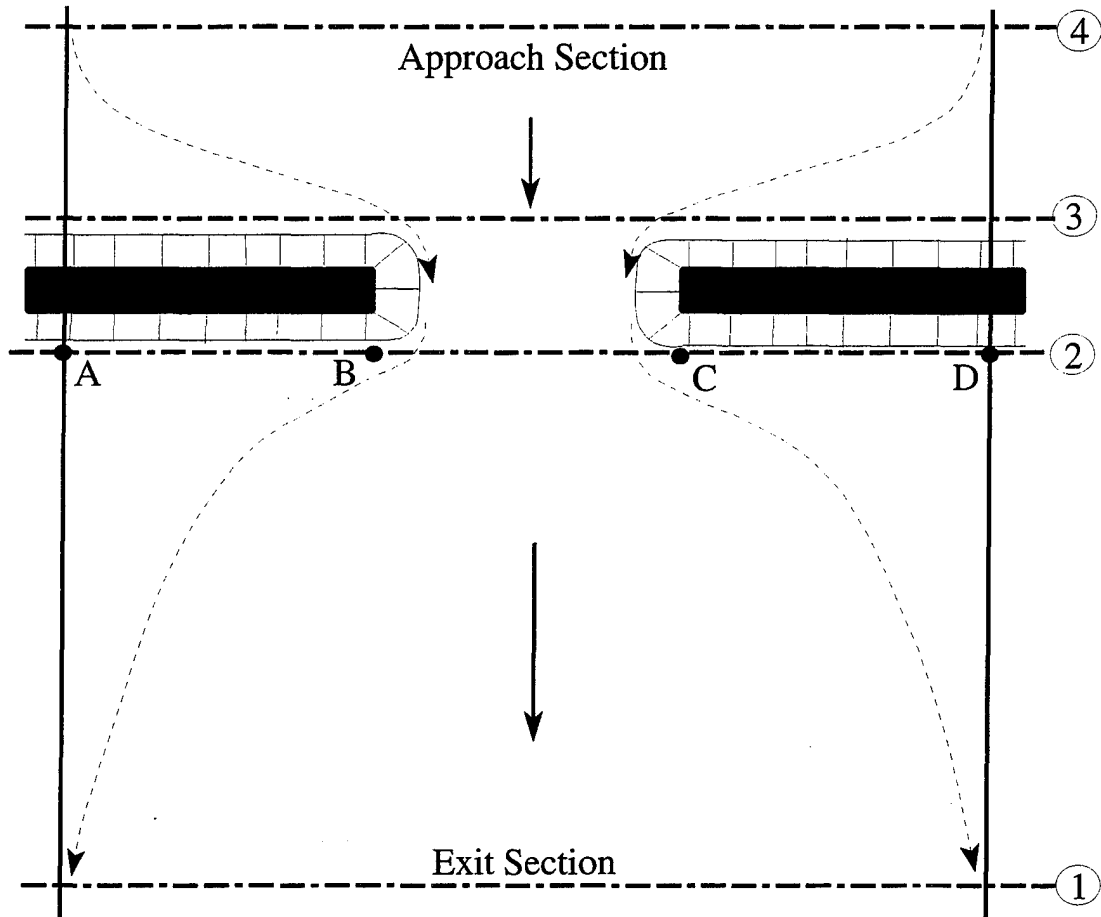

Figure 2. Cross Sections to Model Bridge Flow Transitions

Pressure Flow. When the flow comes into contact with the low chord of the bridge, pressure flow begins. The program uses energy-based (like HEC-2 Normal Bridge) or pressure-flow equations. It checks for the possibility of pressure flow when the upstream energy-grade line goes above the maximum low chord. The user has the option of using the water surface instead of energy elevation. The program will handle two cases of pressure flow. When only the upstream side of the bridge is in contact with the flow, the sluice gate equation is used. If both the upstream and downstream sides of the bridge are in contact with the flow, the full-flow orifice equation is used.

Weir Flow. When water flows over the bridge and/or roadway, the overflow is calculated using a standard weir equation. For high tailwater conditions, the amount of weir flow is reduced to account for the effects of submergence. If the weir becomes highly submerged, the program will switch to calculating energy losses by the standard-step energy method. The criterion for switching to energy-based calculations is user controllable. When combinations of low flow or pressure flow occur with weir flow, an iterative procedure is used to determine the amount of each type of flow.

Culvert hydraulics. The modeling approach for culverts is similar to that for bridges. The cross-section layout, the use of ineffective areas, and the selection of contraction and expansion coefficients are the same. For culvert hydraulics, the program uses the Federal Highway Administrations (FHWA, 1985) culvert equations to model inlet control. Outlet control is analyzed by either direct-step backwater calculations or full-flow friction losses, plus entrance and exit losses. The culvert routines have the ability to model the following shapes: box; circular; arch; pipe arch; and elliptical. Multiple culverts, of different types, can be modeled for a single location.

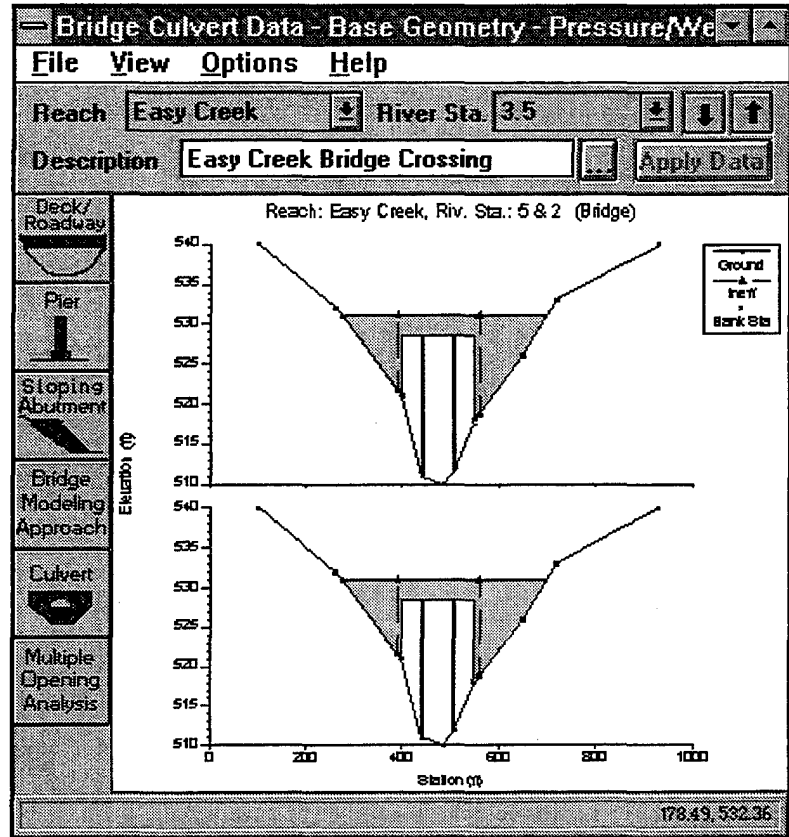

Figure 3. HEC-RAS Bridge Data Editor

Multiple bridge openings. Multiple openings can be modeled by two approaches, as divided flow in two reaches or by the multiple-opening approach. The multiple-opening approach can analyze combinations of three types of openings: bridges, culvert groups, and conveyance areas. Up to seven openings can be defined at any one river crossing. Each opening is evaluated separately and the total flow is distributed such that the energy loss in each is equal.

Bridge Flow Transitions

A Master of Science thesis project (Hunt, 1995) was conducted to investigate bridge expansion and contraction reach lengths and coefficients. Two-dimensional models of idealized bridge crossings were developed using RMA-2V (King, 1994). River slopes, bridge opening widths, overbank to channel *n*-value ratios, and abutment type were varied; a total of 76 cases were modeled. From the model results, regression analyses were performed to develop predictor equations for contraction and expansion reach lengths, ratios, and coefficients. (Figure 4 illustrates the transition lengths and ratios.) The results and general recommendations from this modeling review are summarized here from HEC Research Document No. 42 (HEC, 1995).

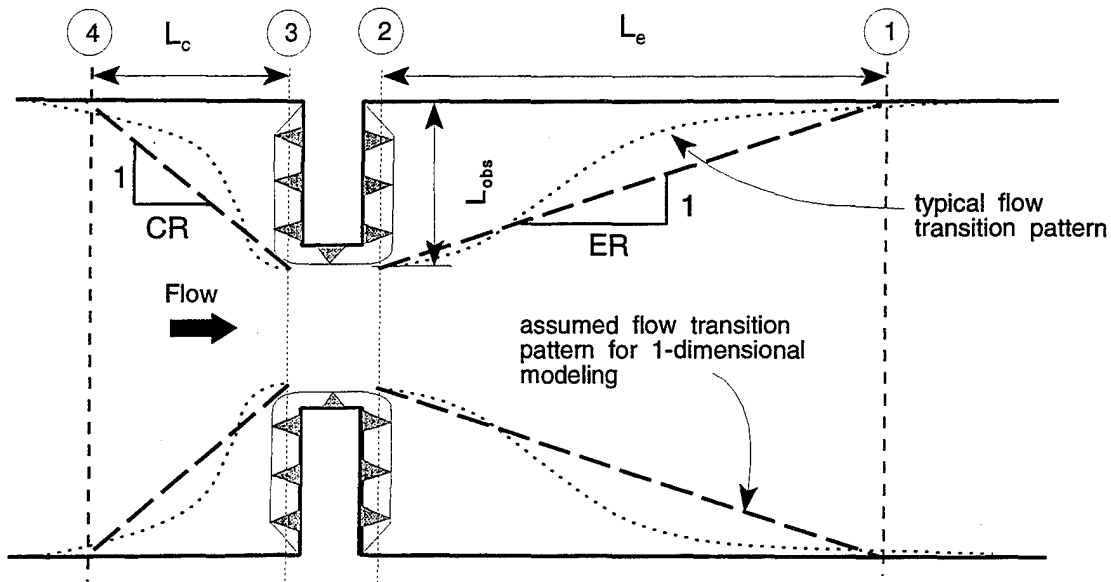

Figure 4. Conceptual Illustration of Transition Reaches

The flow transitions through a bridge crossing, that blocks a portion of the overbank area, is typically modeled with four cross sections. The downstream and upstream sections 1 and 4 represent the full floodplain conveyance. The bridge-bounding cross sections 2 and 3 represent the effective flow area just downstream and upstream from the bridge. The bridge is modeled with the bounding cross sections and additional bridge data. The question is how far does it take for the flow transition to occur, and where to locate the full-flow cross sections 1 and 4.

Expansion Reach Lengths (L_e). The expansion ratio (ER in Fig. 4) was less than 4:1 for all of the idealized cases modeled. The mean and median values of the expansion ratio for the idealized cases were both around 1.5:1. The idealized cases included a wide range of hydraulic and geometric conditions. These observations indicate that the traditional 4:1 rule of thumb will over predict the expansion reach length for most situations.

Many independent variables and combinations of variables were investigated to find a possible correlation with L_e . The variable which showed the greatest correlation was the ratio of the main channel Froude number at the most constricted Section 2 to that at the normal flow Section 1. (See Figure 4 for cross-section references.) The best-fitting equation for the expansion reach length is:

$$L_e = -298 + 257 \left(\frac{F_{c2}}{F_{c1}} \right) + 0.918 (\bar{L}_{obs}) + 0.00479 (Q) \quad (1)$$

for which $\bar{R}^2 = 0.84$ and $S_e = 96$ feet, with

- L_e = length of the expansion reach, in feet,
- F_{c2} = main channel Froude number at Section 2,
- F_{c1} = main channel Froude number at Section 1,
- \bar{L}_{obs} = average length of bridge obstruction, in feet,
- Q = total discharge, cfs,
- \bar{R}^2 = the adjusted determination coefficient (the percentage of variance of the dependent variable from the mean which is explained by the regression equation), and
- S_e = standard error of estimate.

Similarly, the regression equation for the expansion ratio was found to be

$$ER = \frac{L_e}{\bar{L}_{obs}} = 0.421 + 0.485 \left(\frac{F_{c2}}{F_{c1}} \right) + 1.80 \times 10^{-5} (Q) \quad (2)$$

for which $\bar{R}^2 = 0.71$ and $S_e = 0.26$.

Figures 5 and 6 are plots of the observed values versus those predicted by the regression equations for L_e and ER, respectively.

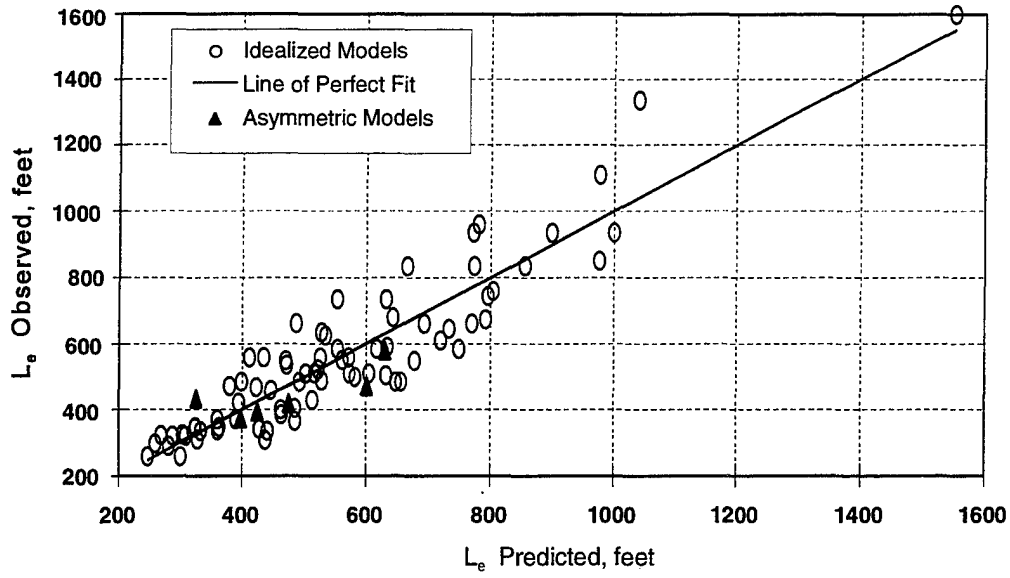

Figure 5. Goodness-of-Fit Plot for Expansion Length Regression Equation (Equation 1).

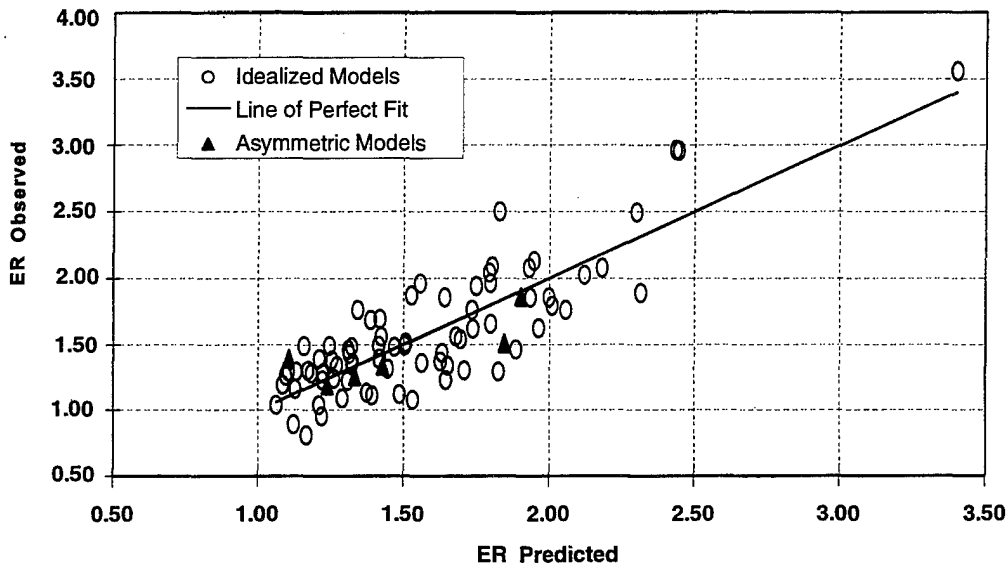

Figure 6. Goodness-of-Fit Plot for Expansion Ratio Regression Equation (Equation 2).

In some studies, a high level of sophistication in the evaluation of the transition reach lengths is not justified. For such studies, and for a starting point in more detailed studies, Table 1 offers ranges of expansion ratios which can be used for different degrees of constriction, different slopes, and different ratios of overbank roughness to main channel roughness. Once an expansion ratio is selected, the distance to the downstream end of the expansion reach (the location of Section 1 on Figure 4) is found by multiplying the expansion ratio by the average obstruction length. The average obstruction length is half of the total reduction in floodplain width caused by the two bridge approach embankments.

In Table 1, b/B is the ratio of the bridge opening width to the total floodplain width, n_{ob} is the Manning n value for the overbank, n_c is the n value for the main channel, and S is the longitudinal slope. The values in the interior of the table are the ranges of the expansion ratio. For each range, the higher value is typically associated with a higher discharge.

Table 1. Ranges of Expansion Ratios

$b/B = 0.10$	Slope:	$n_{ob} / n_c = 1$	$n_{ob} / n_c = 2$	$n_{ob} / n_c = 4$
	1 ft/mile	1.4 - 3.6	1.3 - 3.0	1.2 - 2.1
	5 ft/mile	1.0 - 2.5	0.8 - 2.0	0.8 - 2.0
	10 ft/mile	1.0 - 2.2	0.8 - 2.0	0.8 - 2.0
$b/B = 0.25$	1 ft/mile	1.6 - 3.0	1.4 - 2.5	1.2 - 2.0
	5 ft/mile	1.5 - 2.5	1.3 - 2.0	1.3 - 2.0
	10 ft/mile	1.5 - 2.0	1.3 - 2.0	1.3 - 2.0
$b/B = 0.50$	1 ft/mile	1.4 - 2.6	1.3 - 1.9	1.2 - 1.4
	5 ft/mile	1.3 - 2.1	1.2 - 1.6	1.0 - 1.4
	10 ft/ mile	1.3 - 2.0	1.2 - 1.5	1.0 - 1.4

The ranges in Table 1, as well as the ranges of other parameters to be presented later, capture the ranges of the idealized model data from this study. Extrapolation of expansion ratios for constriction ratios, slopes or roughness ratios outside of the ranges used in this table should be done with care. The expansion ratio should not exceed 4:1, nor should it be less than 0.5:1, unless there is site-specific field information to substantiate such values. The ratio of overbank roughness to main-channel roughness provides information about the relative conveyances of the overbank and main channel.

The user should note that in the data used to develop these recommendations, all cases had a main-channel n value of 0.04. For significantly higher or lower main-channel n values, the n value ratios will have a different meaning with respect to overbank roughness. It is impossible to determine from the data of this study whether this would introduce significant error in the use of these recommendations.

It is recommended that the user start with an expansion ratio from Table 1, locate Section 1 according to that expansion ratio, set the main channel and overbank reach lengths as appropriate, and limit the effective flow area at Section 2 to the approximate bridge opening width. The program should then be run and the main channel Froude numbers at Sections 2 and 1 read from the model output. Use these Froude number values to determine a new expansion length from the appropriate equation, move Section 1 as appropriate and recompute. Unless the geometry is changing rapidly in the vicinity of Section 1, no more than two iterations after the initial run should be required.

When the expansion ratio is large, say greater than 3:1, the resulting reach length may be so long as to require intermediate cross sections which reflect the changing width of the effective flow area. These intermediate sections are necessary to reduce the reach lengths when they would otherwise be too long for the linear approximation of energy loss that is incorporated in the standard step method. These interpolated sections are easy to create in the HEC-RAS program, because it has a graphical cross section interpolation feature. The importance of interpolated sections in a given reach can be tested by first inserting one interpolated section and seeing the effect on the results. If the effect is significant, the subreaches should be subdivided into smaller units until the effect of further subdivision is inconsequential.

Contraction Reach Lengths (L_c). In contrast to the expansion reach length results, the results for contraction lend some support to the traditional rule of thumb which recommends the use of a 1:1 contraction ratio. The range of values for this ratio was from 0.7:1 to 2.3:1. The median and mean values were both around 1.1 to 1.

The Froude number ratio in the previous two equations also proved to be significant in its relationship to the contraction reach length. Surprisingly, the Froude number ratio which involved the upstream (Section 4) Froude number did not have as strong a correlation as the one involving the Section 1 value. Here again the degree of constriction, in comparison with the undisturbed flow condition, is of high significance. The most significant independent variable for this parameter, however, was the percentage of the total discharge conveyed by the two overbanks. The best-fit equation from the regression analysis is

$$L_c = 263 + 38.8 \left(\frac{F_{c2}}{F_{c1}} \right) + 257 \left(\frac{Q_{ob}}{Q} \right)^2 - 58.7 \left(\frac{n_{ob}}{n_c} \right)^{0.5} + 0.161 (\bar{L}_{obs}) \quad (3)$$

with $\bar{R}^2 = 0.87$ and $S_e = 31$ feet. In this equation

Q_{ob} = the discharge conveyed by the two overbank sections, in cfs, and
 n_{ob} = the Manning n value for the overbank sections.

Figure 7 shows the observed versus predicted values for Equation 3. The contraction length values did not vary much as a function of the bridge opening width or the average obstruction length. As a result most of the cases with the widest opening width, and therefore the shortest average obstruction length, had the highest contraction ratios. The numerator of the ratio varied only slightly while the denominator varied greatly.

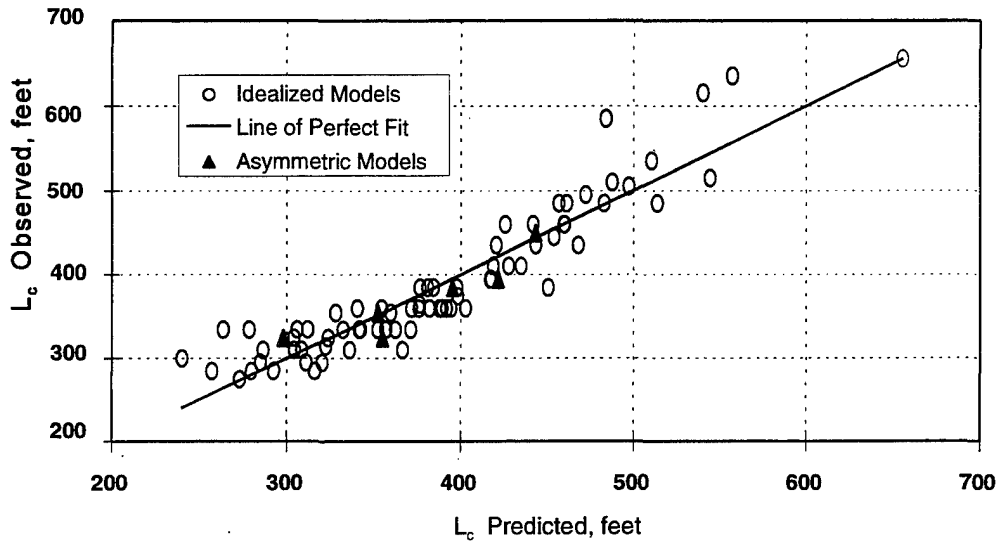

Figure 7. Goodness-of-Fit Plot for Contraction Reach Length Regression Equation (Equation 3).

None of the attempted regression relationships were good predictors of the contraction ratio. Equation 4 provided the best fit of all the combinations of independent variables tried. The scatter around a CR value of 1 is shown in Figure 8, a plot of the observed versus predicted values of the contraction ratio. The regression equation for the contraction ratio is:

$$CR = 1.4 - 0.333 \left(\frac{F_{c2}}{F_{c1}} \right) + 1.86 \left(\frac{Q_{ob}}{Q} \right)^2 - 0.19 \left(\frac{n_{ob}}{n_c} \right)^{0.5} \quad (4)$$

This equation has an $\bar{R}^2 = 0.65$ and $S_e = 0.19$.

An unfortunate feature of this equation is the negative sign on the Froude number ratio term. This negative term indicates that the contraction ratio should become smaller as the constriction gets more severe. Given the low \bar{R}^2 for equation 4, equation 3 is preferable.

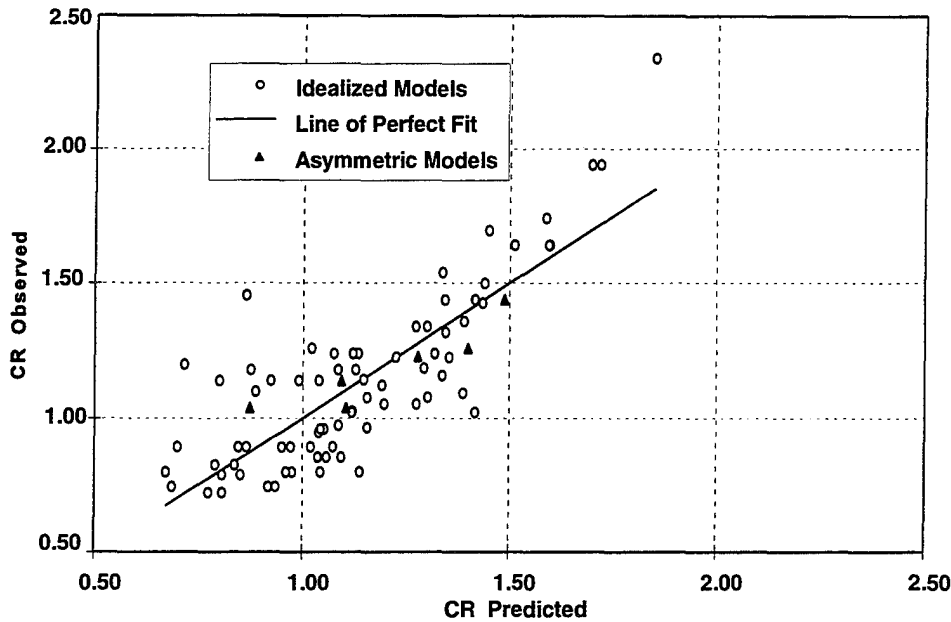

Figure 8. Goodness-of-Fit Plot for Contraction Ratio Regression Equation (Equation 4).

Ranges of contraction ratios for different conditions are presented in Table 2. An average value or a value from the table can be used as a starting estimate and contraction reach length f or studies which do not justify a more detailed evaluation.

Table 2. Ranges of Contraction Ratios

	$n_{ob} / n_c = 1$	$n_{ob} / n_c = 2$	$n_{ob} / n_c = 4$
$S = 1$ ft/mile	1.0 - 2.3	0.8 - 1.7	0.7 - 1.3
5 ft/mile	1.0 - 1.9	0.8 - 1.5	0.7 - 1.2
10 ft/mile	1.0 - 1.9	0.8 - 1.4	0.7 - 1.2

When the conditions are within or near those of the data, the contraction reach length regression Equation 3, may be used. In cases where the floodplain scale and discharge are significantly larger or smaller than those that were used in developing the regression formulae, Equation 3 should not be used. The recommended approach for estimating the contraction ratio at this time is to compute a value from Equation 4 and check it against the values in Table 2. As with the expansion reach lengths, the modeler must use these equations and the values from Table 2 with extreme caution when the prototype is outside of the range of data used in this study. The contraction ratio should not exceed 2.5:1 nor should it be less than 0.3:1.

Expansion Coefficients (C_e). Unlike the transition reach lengths, the transition coefficients did not lend themselves to strong regression relationships. This situation is partly

due to the fact that the velocity head differences were so small in many instances as to render the coefficient values insignificant. Calibration of the coefficients under these conditions is obviously meaningless. Despite these difficulties, some trends were apparent in the expansion coefficient. The ratio of the hydraulic depth on the overbanks to the hydraulic depth in the main channel showed some correlation with C_e . The best regression relationship was:

$$C_e = -0.092 + 0.570 \left(\frac{D_{ob}}{D_c} \right) + 0.075 \left(\frac{F_{c2}}{F_{c1}} \right) \quad (5)$$

for which $\bar{R}^2 = 0.55$ and $S_e = 0.10$, with

- D_{ob} = hydraulic depth (flow area divided by top width) for the overbank at the normal flow section (Section 1), in feet, and
- D_c = hydraulic depth for the main channel at the normal flow section (Section 1), in feet.

Figure 9 shows the goodness of fit for this equation. The analysis of the data with regard to the expansion coefficients did not yield a regression equation which fit the data well. Equation 5 was the best equation obtained for predicting the value of this coefficient. The calibrated expansion coefficients ranged from 0.1 to 0.65. The median value was 0.3. Recalling that the traditional rule of thumb for this coefficient suggests a standard value of 0.5, it appears that the application of this rule could lead to an over prediction of energy loss in the expansion reach.

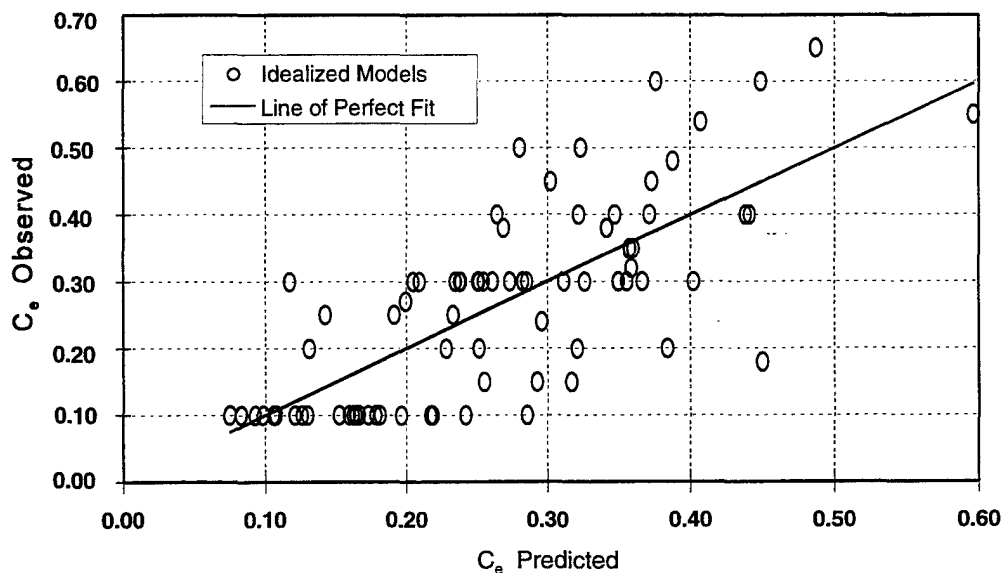

Figure 9. Goodness-of-Fit Plot for Expansion Coefficient Regression Equation (Equation 5).

It is recommended that the modeler use an average value or Equation 5 to find an initial value, then perform a sensitivity analysis using values of the coefficient that are 0.2 higher and 0.2 lower than the initial value. The plus or minus 0.2 range defines the 95% confidence band for Equation 5 as a predictor within the domain of the regression data. If the difference in results between the two ends of this range is substantial, then the conservative value should be used. The expansion coefficient should be higher than the contraction coefficient and less than 1.0.

Contraction Coefficients (C_c). Of the 76 cases used in the regression analysis (those with symmetric openings and spill-through abutments), 69 had calibrated C_c values of 0.10. These included cases for which the contraction coefficient had no appreciable significance, as well as the 28 cases wherein the RMA-2 water surface elevation at the approach section was too low to be reached in HEC-RAS. Because of these conditions, the regression analysis was unfruitful. In addition to the regression study with all of the data, an attempt at regression was made which incorporated only 20 cases. For this analysis those cases in which the contraction coefficient was inconsequential were omitted. This attempt also failed to yield a satisfactory regression relationship because 13 of these 20 cases still had calibrated coefficient values of 0.10.

The values for the contraction coefficient ranged from 0.10 to 0.50. The mean was 0.12 and the median value obviously was 0.10. Here again is a suggestion that the traditional standard value used for bridges, 0.30, is probably too high.

The data of this study did not lend itself to regression of the contraction coefficient values. For nearly all of the cases the value that was determined was 0.1, which was considered to be the minimum acceptable value. The following table presents recommended ranges of the contraction coefficient for various degrees of constriction, for use in the absence of calibration information.

Table 3. Contraction Coefficient Values

Degree of Constriction	Recommended Contraction Coefficient
$0\% < b/B < 25\%$	0.3 - 0.5
$25\% < b/B < 50\%$	0.1 - 0.3
$50\% < b/B < 100\%$	0.1

Summary. The preceding recommendations represent a substantial improvement over the guidance information that was previously available on the evaluation of transition reach lengths and coefficients. They are based on model data which, like all data, have a limited scope of direct application. Certain situations, such as highly skewed bridge crossings and bridges at

locations of sharp curvature in the floodplain were not addressed by this study. Even so, these recommendations may be applicable to such situations if proper care is taken and good engineering judgement is employed.

In applying these recommendations, the modeler should always consider the range of hydraulic and geometric conditions included in the data. Wherever possible, the transition reach lengths used in the model should be validated by field observations of the site in question, preferably under conditions of high discharge. The evaluation of contraction and expansion coefficients should ideally be substantiated by site-specific calibration data, such as stage-discharge measurements upstream of the bridge. The guidelines given here recognize the fact that site-specific field information is often unavailable or very expensive to obtain.

Program Testing

Initial program testing compared HEC-RAS with the results from the current HEC-2 program, primarily evaluating differences in cross-section water-surface elevations. These tests only involved cross-sectional data; no bridges or culverts were in the models. Water surface profile comparisons were made for both the HEC-2 and HEC-RAS approaches for conveyance calculations (Brunner & Bonner, 1994). Ninety-six percent of HEC-RAS elevations were within 6 mm of HEC-2 profile results, when using the HEC-2 conveyance computation option. However, the computed profiles are higher, than those from HEC-2, when the default conveyance computation is used. We believe that the default HEC-RAS method is more consistent with the theory and with computer programs HEC-6 (HEC, 1993), UNET (HEC, 1995d), and WSPRO (FHWA, 1990).

The bridge routines of HEC-RAS, HEC-2, and WSPRO were tested using 21 USGS data sets from the Bay St. Louis Laboratory (Ming et al., 1978). "In general, all models were able to compute water surface profiles within the tolerance of the observed data" (HEC, 1995c). "The variation of the water surface at any given cross section was on the order of 0.1 to 0.3 feet" (ibid). For HEC-RAS and HEC-2, the energy-based methods reproduced observed bridge low-flow losses better than the Yarnell method. Also, the apparent downstream expansion reach-lengths were shorter than rates suggested in HEC guidelines (HEC, 1990). Because all the prototype bridge data came from similar wide, heavily-vegetated flood plains with low velocities, additional research was conducted using the RMA-2V computer program (King, 1994). Application of the 2-D model to the prototype data demonstrated that RMA-2V could reproduce observed bridge-flow depths and transitions. Based on these results, the 2-D program was used to simulate different bridge configurations, as reported in the section Bridge Flow Transitions.

Along with internal HEC testing, two Beta versions were released to the public for testing (250 for Beta 1 and 200 for Beta 2). After all the testing was completed, and final corrections and additions were made, HEC released Version 1.0 in July 1995. Program development continued, as well as error corrections found in Version 1.0. The program update, Version 1.1,

was released in January 1996. Program development on the steady-flow model is expected through fiscal year 1996, when most of the expected features will be completed. After that, work will proceed with the unsteady-flow model.

Acknowledgment

This paper includes the work of several colleagues, including: Mark Jensen, Co-Op Student, who was responsible for the HEC-RAS GUI and graphics, and Steven Piper, Hydraulic Engineer, who developed major portions of the program code. The bridge model comparison and the flow transition analyses were performed by John Hunt, a student intern from UC Davis. Mr. Gary Brunner is team leader for this development project and supervised model testing.

References

- Bonner, Vernon R. and Brunner, Gary, 1994. "HEC River Analysis System (HEC-RAS)," Hydraulic Engineering '94, Volume 1, pages 376-380, *Proceedings for the ASCE 1994 National Conference on Hydraulic Engineering*) Hydrologic Engineering Center (Also as HEC, 1994)
- Brunner, Gary W. and Piper, Steven S., 1994. "Improved Hydraulic Features of the HEC River Analysis System (HEC-RAS)," Hydraulic Engineering '94, Volume 1, pages 502-506, *Proceedings for the ASCE 1994 National Conference on Hydraulic Engineering*. (Also as HEC, 1994)
- Federal Highway Administration (FHWA), 1985. "Hydraulic Design of Highway Culverts," Hydraulic Design Series No. 5, US Department of Transportation, Washington, DC.
- FHWA, 1990. "User's Manual for WSPRO - A computer model for water surface profile computations," Publication No. FHWA-IP-89-027, Washington, DC.
- HEC, 1990. "HEC-2 Water Surface Profiles," User's Manual, Davis, CA, September 1990 .
- HEC, 1993. "HEC-6 Scour and Deposition in Rivers and Reservoirs," User's Manual, Davis, CA, August 1993.
- HEC, 1994. "HEC River Analysis System (HEC-RAS)," Technical Paper No. 147, Davis, CA, August 1994. (Combining Bonner and Brunner papers presented at ASCE Hydraulic Engineering '94)
- HEC, 1995a. "HEC-RAS River Analysis System", User's Manual, Davis, CA, July 1995.

HEC, 1995b. HEC-RAS River Analysis System," Hydraulic Reference Manual, Davis, CA, July 1995.

HEC, 1995c. "Comparison of the One-Dimensional Bridge Hydraulic Routines from: HEC-RAS, HEC-2 and WSPRO," Research Document No. 41, Davis, CA, September 1995.

HEC, 1995d. "UNET One-dimensional Unsteady Flow Through a Full Network of Open Channels," User's Manual, Davis, CA September 1995.

Hunt, John, 1995. "Flow Transitions in Bridge Backwater Analysis," Masters of Science Thesis, University of California at Davis. (Also, published as Hydrologic Engineering Center Research Document No. 42, Davis, CA, September 1995.)

King, Ian P., 1994. "RMA-2V Two-Dimensional Finite Element Hydrodynamic Model," Resource Management Associates, Lafayette, CA.

Ming, C.O., Colson, B.E. and G.J. Arcement, 1978. "Backwater at Bridges and Densely Wooded Flood Plains," Hydrologic Investigation Atlas Series, U.S. Geological Survey.

REPORT DOCUMENTATION PAGE

Form Approved
OMB No. 0704-0188

Public reporting burden for this collection of information is estimated to average 1 hour per response, including the time for reviewing instructions, searching existing data sources, gathering and maintaining the data needed, and completing and reviewing the collection of information. Send comments regarding this burden estimate or any other aspect of this collection of information, including suggestions for reducing this burden, to Washington Headquarters Services, Directorate for Information Operations and Reports, 1215 Jefferson Davis Highway, Suite 1204, Arlington, VA 22202-4302, and to the Office of Management and Budget, Paperwork Reduction Project (0704-0188), Washington, DC 20503.

1. AGENCY USE ONLY (Leave blank)	2. REPORT DATE April 1996	3. REPORT TYPE AND DATES COVERED Technical Paper	
4. TITLE AND SUBTITLE Bridge Hydraulic Analysis with HEC-RAS		5. FUNDING NUMBERS	
6. AUTHOR(S) Vernon Bonner and Gary Brunner		8. PERFORMING ORGANIZATION REPORT NUMBER Technical Paper No. 151	
7. PERFORMING ORGANIZATION NAME(S) AND ADDRESS(ES) Hydrologic Engineering Center 609 Second Street Davis, California 95616-4687		10. SPONSORING / MONITORING AGENCY REPORT NUMBER	
9. SPONSORING / MONITORING AGENCY NAME(S) AND ADDRESS(ES)		11. SUPPLEMENTARY NOTES Paper presented at the Association of State Floodplain Managers 20th Annual Conference, 10-14 June 1996, San Diego, CA.	
12a. DISTRIBUTION / AVAILABILITY STATEMENT Unlimited		12b. DISTRIBUTION CODE	
13. ABSTRACT (Maximum 200 words) The Hydrologic Engineering Center (HEC) is developing next generation software for one-dimensional river hydraulics. The HEC-RAS River Analysis System is intended to be the successor to the current steady-flow HEC-2 Water Surface Profiles Program as well as provide unsteady flow, sediment transport, and hydraulic design capabilities in the future. A common data representation of a river network and bridge data is used by all modeling methods. This paper presents the bridge modeling approach, available methods, and research results on flow transitions and associated modeling guidelines.			
14. SUBJECT TERMS Water surface profiles, bridge hydraulics, HEC-RAS computer program, microcomputer			15. NUMBER OF PAGES 17
17. SECURITY CLASSIFICATION OF REPORT Unclassified			16. PRICE CODE
18. SECURITY CLASSIFICATION OF THIS PAGE	19. SECURITY CLASSIFICATION OF ABSTRACT	20. LIMITATION OF ABSTRACT	

TECHNICAL PAPER SERIES

- TP-1 Use of Interrelated Records to Simulate Streamflow
- TP-2 Optimization Techniques for Hydrologic Engineering
- TP-3 Methods of Determination of Safe Yield and Compensation Water from Storage Reservoirs
- TP-4 Functional Evaluation of a Water Resources System
- TP-5 Streamflow Synthesis for Ungaged Rivers
- TP-6 Simulation of Daily Streamflow
- TP-7 Pilot Study for Storage Requirements for Low Flow Augmentation
- TP-8 Worth of Streamflow Data for Project Design - A Pilot Study
- TP-9 Economic Evaluation of Reservoir System Accomplishments
- TP-10 Hydrologic Simulation in Water-Yield Analysis
- TP-11 Survey of Programs for Water Surface Profiles
- TP-12 Hypothetical Flood Computation for a Stream System
- TP-13 Maximum Utilization of Scarce Data in Hydrologic Design
- TP-14 Techniques for Evaluating Long-Term Reservoir Yields
- TP-15 Hydrostatistics - Principles of Application
- TP-16 A Hydrologic Water Resource System Modeling Techniques
- TP-17 Hydrologic Engineering Techniques for Regional Water Resources Planning
- TP-18 Estimating Monthly Streamflows Within a Region
- TP-19 Suspended Sediment Discharge in Streams
- TP-20 Computer Determination of Flow Through Bridges
- TP-21 An Approach to Reservoir Temperature Analysis
- TP-22 A Finite Difference Method for Analyzing Liquid Flow in Variably Saturated Porous Media
- TP-23 Uses of Simulation in River Basin Planning
- TP-24 Hydroelectric Power Analysis in Reservoir Systems
- TP-25 Status of Water Resource Systems Analysis
- TP-26 System Relationships for Panama Canal Water Supply
- TP-27 System Analysis of the Panama Canal Water Supply
- TP-28 Digital Simulation of an Existing Water Resources System
- TP-29 Computer Applications in Continuing Education
- TP-30 Drought Severity and Water Supply Dependability
- TP-31 Development of System Operation Rules for an Existing System by Simulation
- TP-32 Alternative Approaches to Water Resource System Simulation
- TP-33 System Simulation for Integrated Use of Hydroelectric and Thermal Power Generation
- TP-34 Optimizing Flood Control Allocation for a Multipurpose Reservoir
- TP-35 Computer Models for Rainfall-Runoff and River Hydraulic Analysis
- TP-36 Evaluation of Drought Effects at Lake Atitlan
- TP-37 Downstream Effects of the Levee Overtopping at Wilkes-Barre, PA, During Tropical Storm Agnes
- TP-38 Water Quality Evaluation of Aquatic Systems
- TP-39 A Method for Analyzing Effects of Dam Failures in Design Studies
- TP-40 Storm Drainage and Urban Region Flood Control Planning
- TP-41 HEC-5C, A Simulation Model for System Formulation and Evaluation
- TP-42 Optimal Sizing of Urban Flood Control Systems
- TP-43 Hydrologic and Economic Simulation of Flood Control Aspects of Water Resources Systems
- TP-44 Sizing Flood Control Reservoir Systems by Systems Analysis
- TP-45 Techniques for Real-Time Operation of Flood Control Reservoirs in the Merrimack River Basin
- TP-46 Spatial Data Analysis of Nonstructural Measures
- TP-47 Comprehensive Flood Plain Studies Using Spatial Data Management Techniques
- TP-48 Direct Runoff Hydrograph Parameters Versus Urbanization
- TP-49 Experience of HEC in Disseminating Information on Hydrological Models
- TP-50 Effects of Dam Removal: An Approach to Sedimentation
- TP-51 Design of Flood Control Improvements by Systems Analysis: A Case Study
- TP-52 Potential Use of Digital Computer Ground Water Models
- TP-53 Development of Generalized Free Surface Flow Models Using Finite Element Techniques
- TP-54 Adjustment of Peak Discharge Rates for Urbanization
- TP-55 The Development and Servicing of Spatial Data Management Techniques in the Corps of Engineers
- TP-56 Experiences of the Hydrologic Engineering Center in Maintaining Widely Used Hydrologic and Water Resource Computer Models
- TP-57 Flood Damage Assessments Using Spatial Data Management Techniques
- TP-58 A Model for Evaluating Runoff-Quality in Metropolitan Master Planning
- TP-59 Testing of Several Runoff Models on an Urban Watershed
- TP-60 Operational Simulation of a Reservoir System with Pumped Storage
- TP-61 Technical Factors in Small Hydropower Planning
- TP-62 Flood Hydrograph and Peak Flow Frequency Analysis
- TP-63 HEC Contribution to Reservoir System Operation
- TP-64 Determining Peak-Discharge Frequencies in an Urbanizing Watershed: A Case Study
- TP-65 Feasibility Analysis in Small Hydropower Planning
- TP-66 Reservoir Storage Determination by Computer Simulation of Flood Control and Conservation Systems
- TP-67 Hydrologic Land Use Classification Using LANDSAT
- TP-68 Interactive Nonstructural Flood-Control Planning
- TP-69 Critical Water Surface by Minimum Specific Energy Using the Parabolic Method
- TP-70 Corps of Engineers Experience with Automatic Calibration of a Precipitation-Runoff Model
- TP-71 Determination of Land Use from Satellite Imagery for Input to Hydrologic Models
- TP-72 Application of the Finite Element Method to Vertically Stratified Hydrodynamic Flow and Water Quality

- TP-73 Flood Mitigation Planning Using HEC-SAM
TP-74 Hydrographs by Single Linear Reservoir Model
- TP-75 HEC Activities in Reservoir Analysis
TP-76 Institutional Support of Water Resource Models
- TP-77 Investigation of Soil Conservation Service Urban Hydrology Techniques
- TP-78 Potential for Increasing the Output of Existing Hydroelectric Plants
- TP-79 Potential Energy and Capacity Gains from Flood Control Storage Reallocation at Existing U. S. Hydropower Reservoirs
- TP-80 Use of Non-Sequential Techniques in the Analysis of Power Potential at Storage Projects
- TP-81 Data Management Systems for Water Resources Planning
- TP-82 The New HEC-1 Flood Hydrograph Package
- TP-83 River and Reservoir Systems Water Quality Modeling Capability
- TP-84 Generalized Real-Time Flood Control System Model
- TP-85 Operation Policy Analysis: Sam Rayburn Reservoir
- TP-86 Training the Practitioner: The Hydrologic Engineering Center Program
- TP-87 Documentation Needs for Water Resources Models
- TP-88 Reservoir System Regulation for Water Quality Control
- TP-89 A Software System to Aid in Making Real-Time Water Control Decisions
- TP-90 Calibration, Verification and Application of a Two-Dimensional Flow Model
- TP-91 HEC Software Development and Support
- TP-92 Hydrologic Engineering Center Planning Models
- TP-93 Flood Routing Through a Flat, Complex Flood Plain Using a One-Dimensional Unsteady Flow Computer Program
- TP-94 Dredged-Material Disposal Management Model
- TP-95 Infiltration and Soil Moisture Redistribution in HEC-1
- TP-96 The Hydrologic Engineering Center Experience in Nonstructural Planning
- TP-97 Prediction of the Effects of a Flood Control Project on a Meandering Stream
- TP-98 Evolution in Computer Programs Causes Evolution in Training Needs: The Hydrologic Engineering Center Experience
- TP-99 Reservoir System Analysis for Water Quality
- TP-100 Probable Maximum Flood Estimation - Eastern United States
- TP-101 Use of Computer Program HEC-5 for Water Supply Analysis
- TP-102 Role of Calibration in the Application of HEC-6
- TP-103 Engineering and Economic Considerations in Formulating
- TP-104 Modeling Water Resources Systems for Water Quality
- TP-105 Use of a Two-Dimensional Flow Model to Quantify Aquatic Habitat
- TP-106 Flood-Runoff Forecasting with HEC-1F
- TP-107 Dredged-Material Disposal System Capacity Expansion
- TP-108 Role of Small Computers in Two-Dimensional Flow Modeling
- TP-109 One-Dimensional Model For Mud Flows
- TP-110 Subdivision Froude Number
- TP-111 HEC-5Q: System Water Quality Modeling
- TP-112 New Developments in HEC Programs for Flood Control
- TP-113 Modeling and Managing Water Resource Systems for Water Quality
- TP-114 Accuracy of Computed Water Surface Profiles - Executive Summary
- TP-115 Application of Spatial-Data Management Techniques in Corps Planning
- TP-116 The HEC's Activities in Watershed Modeling
- TP-117 HEC-1 and HEC-2 Applications on the MicroComputer
- TP-118 Real-Time Snow Simulation Model for the Monongahela River Basin
- TP-119 Multi-Purpose, Multi-Reservoir Simulation on a PC
- TP-120 Technology Transfer of Corps' Hydrologic Models
- TP-121 Development, Calibration and Application of Runoff Forecasting Models for the Allegheny River Basin
- TP-122 The Estimation of Rainfall for Flood Forecasting Using Radar and Rain Gage Data
- TP-123 Developing and Managing a Comprehensive Reservoir Analysis Model
- TP-124 Review of the U.S. Army Corps of Engineering Involvement With Alluvial Fan Flooding Problems
- TP-125 An Integrated Software Package for Flood Damage Analysis
- TP-126 The Value and Depreciation of Existing Facilities: The Case of Reservoirs
- TP-127 Floodplain-Management Plan Enumeration
- TP-128 Two-Dimensional Floodplain Modeling
- TP-129 Status and New Capabilities of Computer Program HEC-6: "Scour and Deposition in Rivers and Reservoirs"
- TP-130 Estimating Sediment Delivery and Yield on Alluvial Fans
- TP-131 Hydrologic Aspects of Flood Warning - Preparedness Programs
- TP-132 Twenty-five Years of Developing, Distributing, and Supporting Hydrologic Engineering Computer Programs
- TP-133 Predicting Deposition Patterns in Small Basins
- TP-134 Annual Extreme Lake Elevations by Total Probability Theorem
- TP-135 A Muskingum-Cunge Channel Flow Routing Method for Drainage Networks
- TP-136 Prescriptive Reservoir System Analysis Model - Missouri River System Application
- TP-137 A Generalized Simulation Model for Reservoir System Analysis
- TP-138 The HEC NexGen Software Development Project
- TP-139 Issues for Applications Developers
- TP-140 HEC-2 Water Surface Profiles Program
- TP-141 HEC Models for Urban Hydrologic Analysis
- TP-142 Systems Analysis Applications at the Hydrologic Engineering Center
- TP-143 Runoff Prediction Uncertainty for Ungauged Agricultural Watersheds
- TP-144 Review of GIS Applications in Hydrologic Modeling
- TP-145 Application of Rainfall-Runoff Simulation for Flood Forecasting
- TP-146 Application of the HEC Prescriptive Reservoir Model in the Columbia River System
- TP-147 HEC River Analysis System (HEC-RAS)
- TP-148 HEC-6: Reservoir Sediment Control Applications
- TP-149 The Hydrologic Modeling System (HEC-HMS): Design and Development Issues
- TP-150 The HEC Hydrologic Modeling System
- TP-151 Bridge Hydraulic Analysis with HEC-RAS